



## Double Cone Mixer

The MIXACO Tumble Mixer: Gentle Homogenization Economically Implemented

FAST | COST-EFFICIENT | RELIABLE

# Function

The Double Cone Mixer (DCM) consists of two mobile mixing containers of the same size and the tumbling mixer itself. For the mixing process, an empty mixing container is moved by the operator to the tumbling mixer. The container, which is loose on the mobile trolley, is lifted to the mixing head by the pneumatic lift and securely locked there. After the rotating mixing head has been swiveled by 180°, the second mobile mixing container with the material to be mixed is lifted to the mixing head in the same way and locked in place. The mobile trolley remains in the mixer.

By means of the PLC control, the mixing process is started via an operator controlled program. After the mixer starts, both mixing containers continuously rotate at an adjustable speed around the swivel axis of the mixing head. Due to a fixed internal material blade in the mixing head, the material is optimally distributed and deflected during the tumbling motion.

After the preset mixing time has elapsed, the mixing process is stopped. The lower container with the material can be lowered onto the transport trolley and removed from the mixer by the operator. The material can be emptied via the outlet at the bottom of the mixing container.

The tumbling mixer DCM is therefore the ideal solution for the gentle homogenization of multiple mixing batches.

The easy handling and excellent accessibility of all machine components for cleaning make the the DCM tumbling mixer an economical solution for simple mixing tasks and post blending.

## OPERATING PRINCIPLE

# Operating modes of the Double Cone Mixer DCM

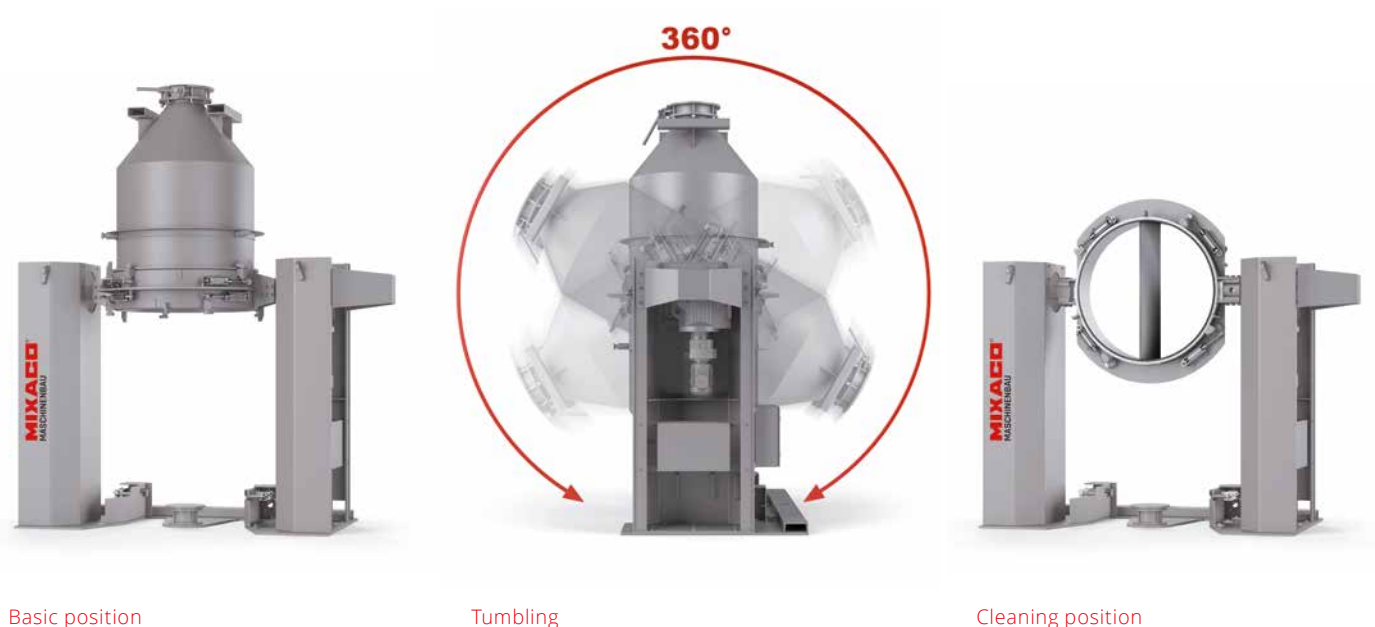

Basic position

Tumbling

Cleaning position

# Details

## Mixing segment

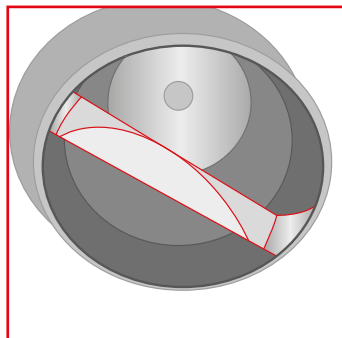

Due to the fixed internal material blade, the material is optimally deflected and mixed during the tumbling process. An even distribution of the materials involved in the mixing process is thus ensured.

## Transmission unit

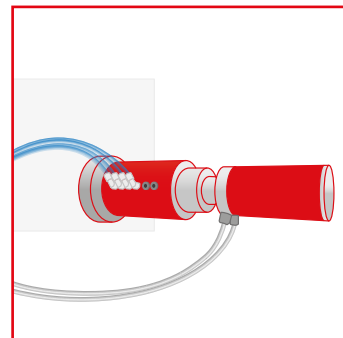

The rotary unit ensures a safe transport of the operating media (e.g. compressed air) to the rotating mixing head.

## Container platform

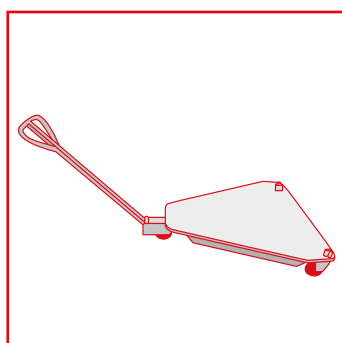

The container platform, which has proven itself in practice, ensures safe transport of the container from the charging to the double cone mixer DCM or to the discharge device. At the same time, a trolley is used to pick up and transport of the container after mixing.

## Lifting cylinder

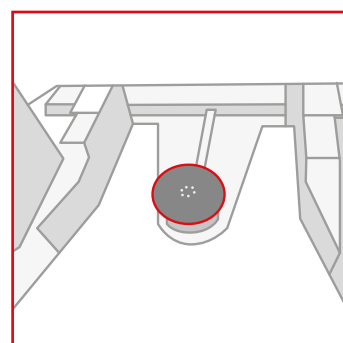

The lifting cylinder enables the precise lifting of the container from the container trolley to the mixing head and back again to the trolley.

## THE REMOTE MAINTENANCE

### Remote maintenance module

The remote maintenance module enables fast and secure access to the combined mixer controller via a VPN tunnel. This in turn allows our service team to diagnose and rectify any malfunctions without requiring a physical visit the site.

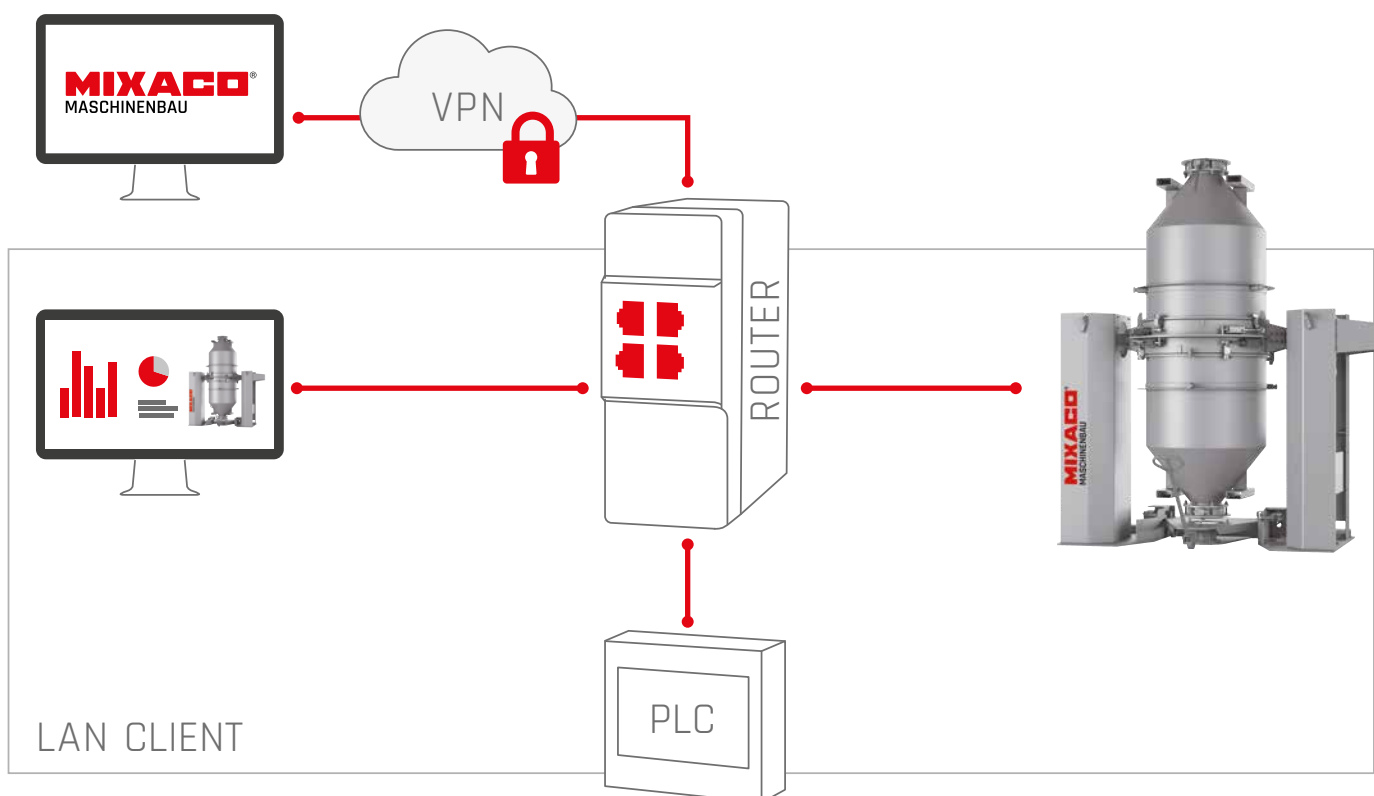

# Technical Data

## Best mixing quality for a wide variety of applications

PVC | POWDER COATING | MASTERBATCHES | AND MANY MORE

### Maximum functionality

Usable as

- Granule mixer
- Powder mixer
- Tumble mixer
- Cone mixer
- Batch mixer



Sizes	Usable volume Liters	Batch size kg	Mixing time min / Batch
<b>Double Cone Mixer</b>			
DCM 450	450	225	3-6
DCM 600	600	300	3-6
DCM 800	800	400	3-6
DCM 1000	1000	500	3-6
DCM 1300	1300	650	3-6
DCM 2000	2000	1000	3-6

Parameters	
Bulk density	0.5 kg/l
Filling level	max. 50 %
Charging	manual
Additional sizes available on request	

# Experience in Many Industries

MIXACO has been offering solutions for a wide variety of industries for many decades. This means the requirements on the mixing technology are correspondingly varied. MIXACO has profound expertise across many industries and can precisely and positively adapt the wide product assortment to each individual mixing task.

Especially in the field of double cone mixers, the customer benefits from comprehensive consulting and the development of customer-specific solutions. Whether new projects or the optimization of existing plants, MIXACO will be by your side throughout a successful installation and commissioning.

No other company stands for innovation in mixing technology like MIXACO, who has been setting new standards with its machinery and solutions for decades. Leading companies from numerous industries worldwide trust in MIXACO products.



Powder Coatings /  
Bonding



Masterbatches



Food Industry



Rubber Industry



Paint Industry



Building Materials

## Save the Best for Last

### All advantages at a glance:

- Existing on-site Mixaco containers with mobile trolley can be used if necessary
- Gentle homogenization
- Lowest energy input
- No active mixing tools
- Up to 2000 liters
- Executions: Painted steel or stainless steel
- Standalone design
- Various safety enclosures available, such as protective grids, safety doors, or light barriers
- Containers can be used for downstream processes with MIXACO's Container Discharge Stations, which require no transfer into another container
- Higher production time of the mixer due to the cleaning of the mixing vessel external to the mixer

Good ideas are conceived.  
But the right solutions are put to the test.



Contact us for your mixing trials and benefit from the extensive experience of our design and application engineers:

- Tests on various mixing systems
- Adaptation of mixing parameters
- Recording and documentation of mixing tests
- Analysis of mixing results



## MIXACO

Dr. Herfeld GmbH & Co. KG

Niederheide 2  
58809 Neuenrade  
Deutschland

Phone +49 2392 9644-0  
Fax +49 2392 62013  
info@mixaco.de

MIXACO USA LLC

1784 Poplar Drive  
Greer, SC 29651  
USA

Phone +1 864 331 23 20  
Fax +1 864 331 23 21  
info@mixaco.com