

CONTAINER MIXER  
MULTITOOL™

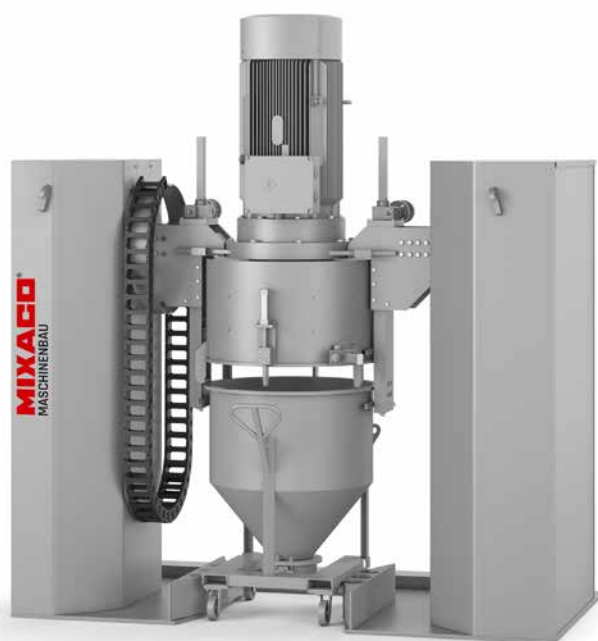

CONTAINER MIXER  
VORTEX™

## Container mixer

The variety in a mixing process

INDIVIDUALLY CONFIGURABLE | EFFICIENT MATERIAL LOGISTICS | HIGHLY FLEXIBLE

# Function

## One mixer - the highest quality

In 1975, the first container mixer changed mixing technology throughout the world. And we invented it!

The MIXACO container mixer is suited for use in all fields where valuable materials and resources need to be mixed together. Thanks to its numerous custom tool options, the desired mixing results can be achieved reliably.

The mobile stainless steel MIXACO container equipped with wheels is filled with raw materials and then pushed towards the container mixer by the operator. In this phase, the container is used as a transport container. In the container mixer, the container is connected to the mixing head and tilted 180° into the **mixing position**. During the mixing process, the container together with the mixing head is therefore used as a mixing chamber.

After mixing, the container is tilted back to the **basic position**. The container with the finished mixed material is removed from the mixer, and can now be transported directly for further processing without decanting to a different receptacle. In this phase, the container is once again used as a transport container.

For fast and residue-free cleaning of the mixing head, the container mixer is tilted into the **cleaning position** without container.

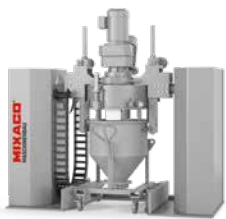

Basic position



Mixing position



Cleaning position

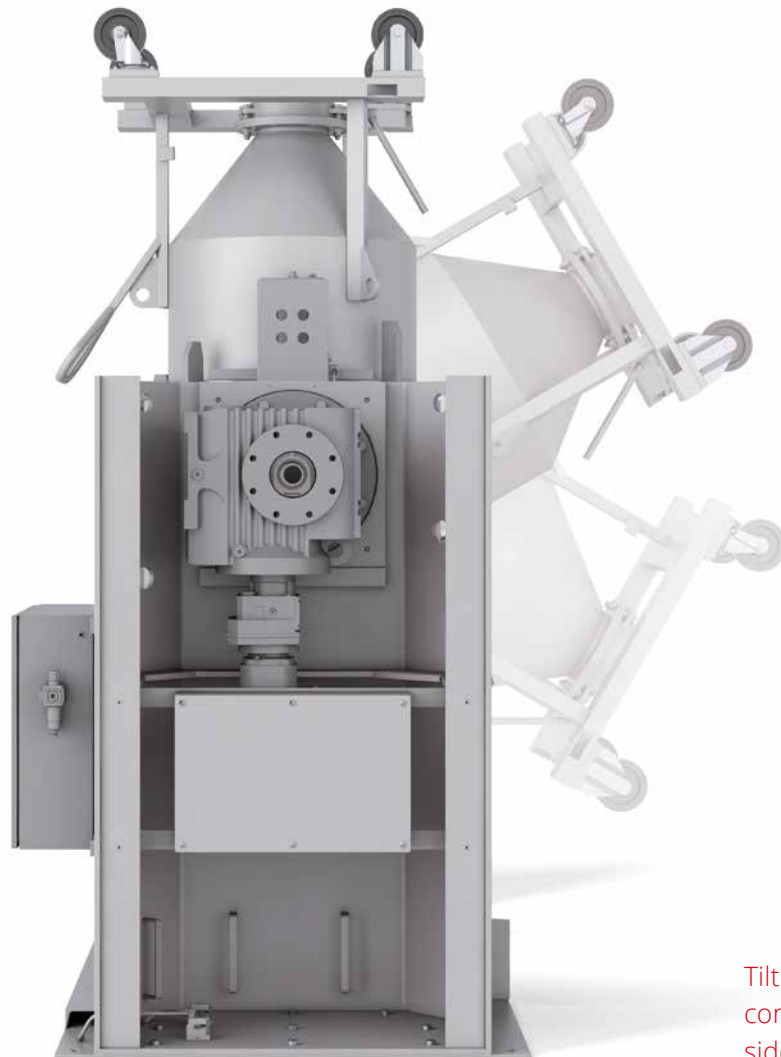

Tilting process of a container mixer, side view

# Handling

## Material flow

For container handling during loading and discharging, MIXACO provides appropriate accessories. Using individually configurable loading and emptying equipment, the container can be filled dust-free or can be discharged into the extruder or weighing/bagging equipment.

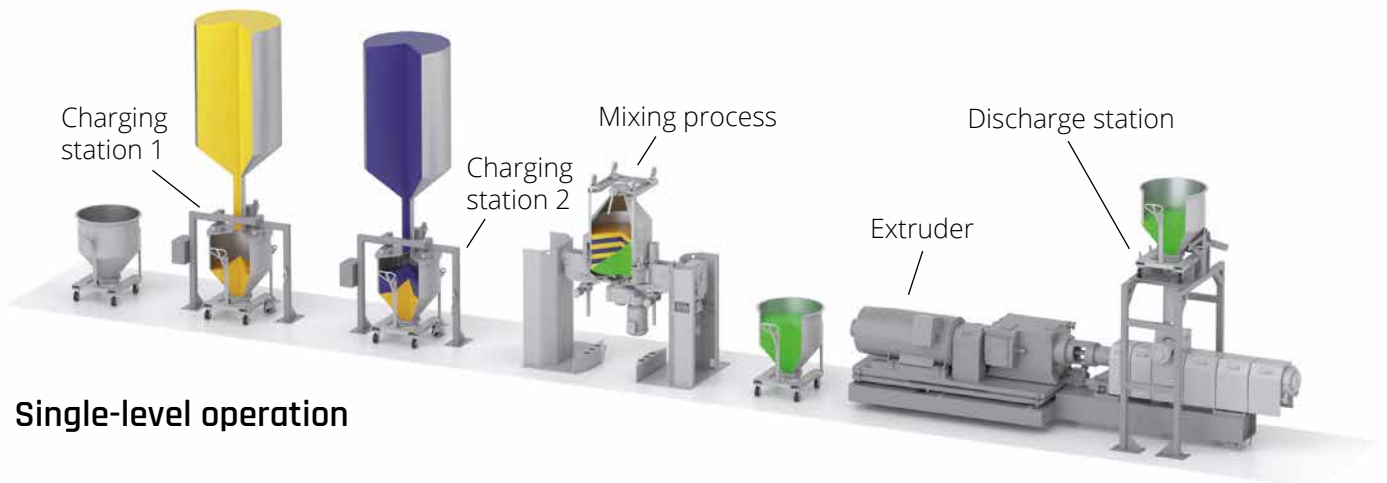

## Single-level operation

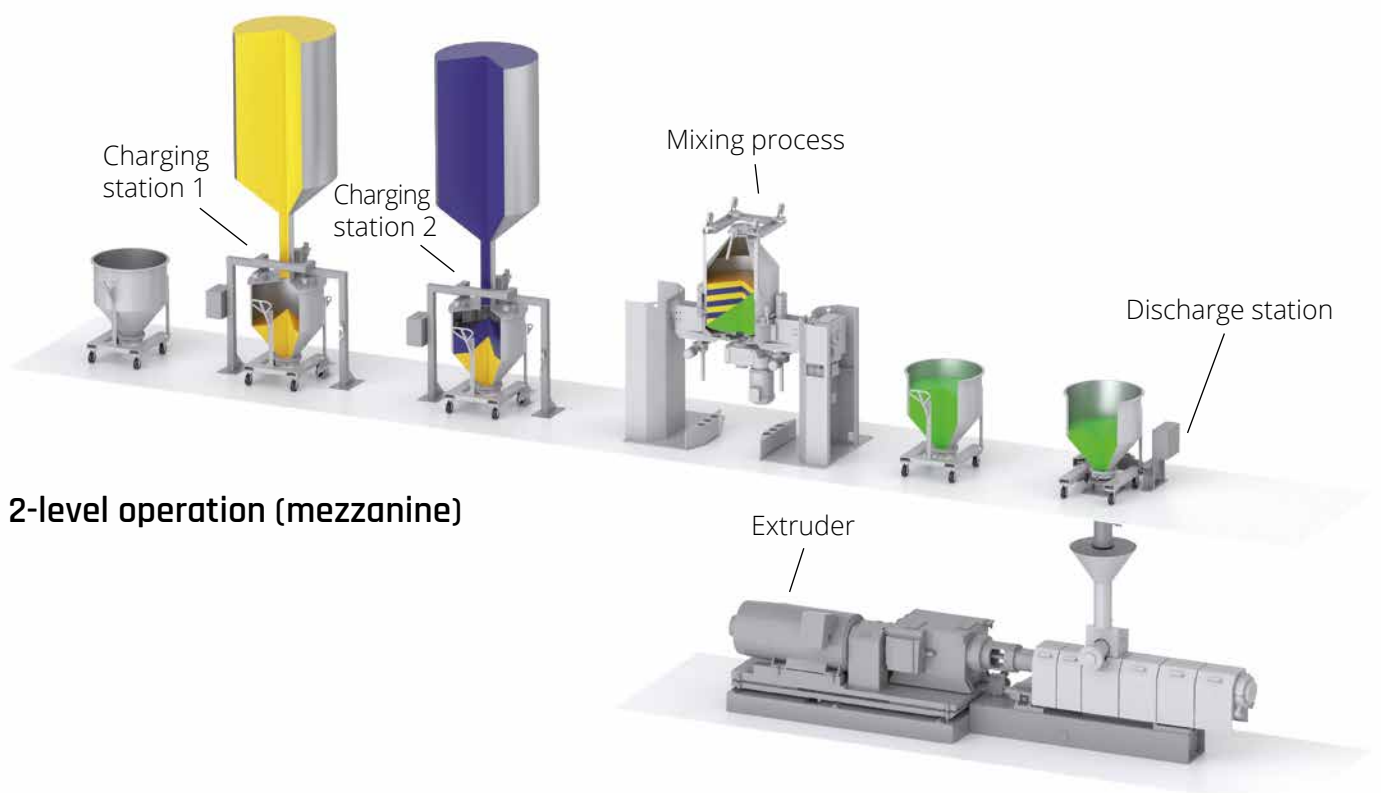

## 2-level operation (mezzanine)

# The patented MIXACO Multitool™

## Particularly well suited for mixing temperature-sensitive materials

The MIXACO Multitool™ container mixer is particularly well suited for mixing temperature-sensitive materials. Mixing without a temperature increase is made possible using an innovative and patented mixing procedure. In this process, the tools generate varying material streams in the mixer which significantly reduce the heating of the mix.

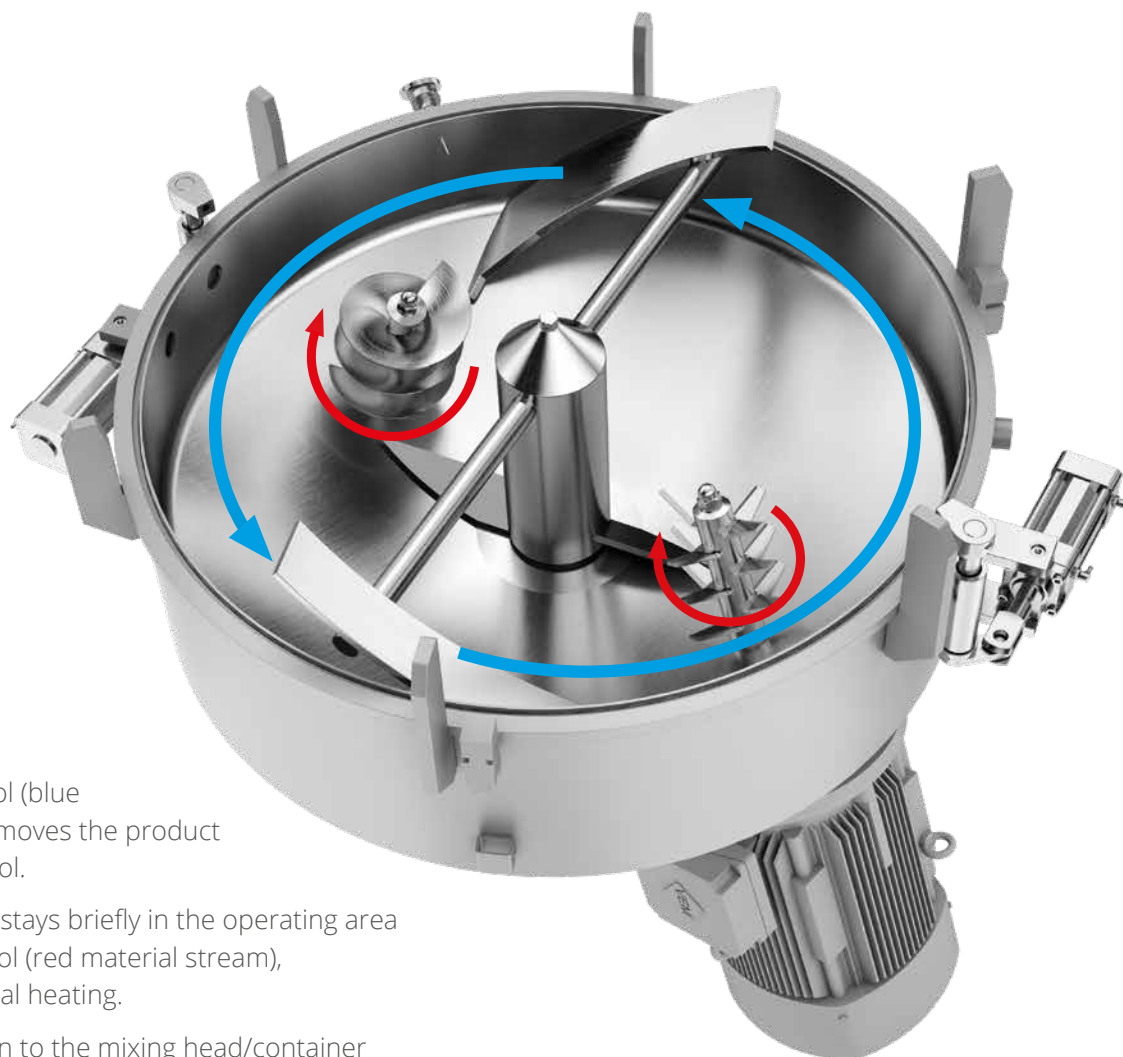
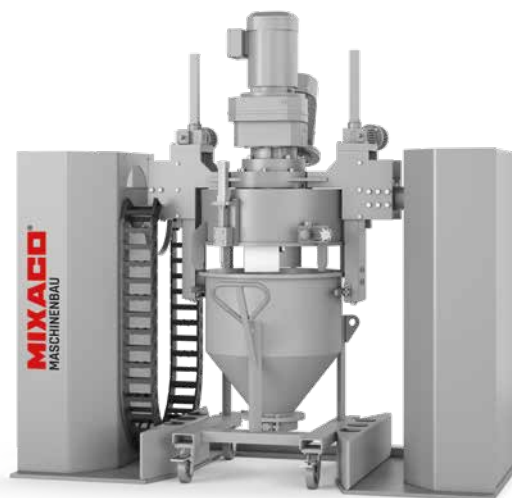

### Mixing process

- The conveying tool (blue material stream) moves the product to the auxiliary tool.
- The product only stays briefly in the operating area of the auxiliary tool (red material stream), generating minimal heating.
- Reduced adhesion to the mixing head/container
- Energy savings due to low drive power
- No mixing vortex is generated during the mixing process.
- By selecting the auxiliary tool, various mixing tasks can be carried out highly dispersive or gentle to material.

# Tools

## Best mixing quality for a wide variety of applications

POWDER COATING | MASTERBATCH | COMPOUNDS | PVC | AND MANY MORE

The respective conveying tool moves the product towards the auxiliary tool (see below). The shape and circumferential speed of the conveying tool affects the material transport towards the auxiliary tool and the mixing of the materials.



### Conveying tool „Push“

- 3–4 m/s



### Conveying tool „Pull“

- 1–2 m/s

## Auxiliary tools

At least one auxiliary tool is installed in the base of the mixing head. Depending on the mixing task, the appropriate tool design can be used or easily exchanged. We will determine the appropriate tools for your product in a joint mixing trial.



### Chopper

- Homogenization & Dispersing
- 30–40 m/s
- Highly dispersive / high shearing force
- Used for intensive crushing of product agglomerates



### Paddle

- Homogenization
- 15–20 m/s
- Reduced shearing force compared with the chopper



### Screw

- Gentle homogenization
- 1–15 m/s
- Minimum shearing force

# The standard execution – MIXACO Vortex™

## The right mix is always guaranteed

For more than 40 years, this type of mixer has been used in a wide variety of applications, such as mixing powder coatings, masterbatches, toners (premixed or post blending), color concentrates, additives, and much more. In contrast to the Multitool™ container mixer, the Vortex™ container mixer generates a so-called mixing vortex during the mixing process. In this process, the mix is carried upwards over the base of the mixing head by the rotation of the mixing tools and falls back down in the center again due to gravity.

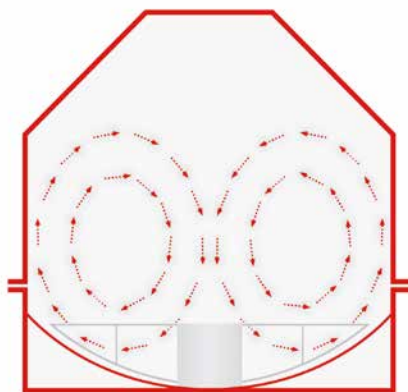
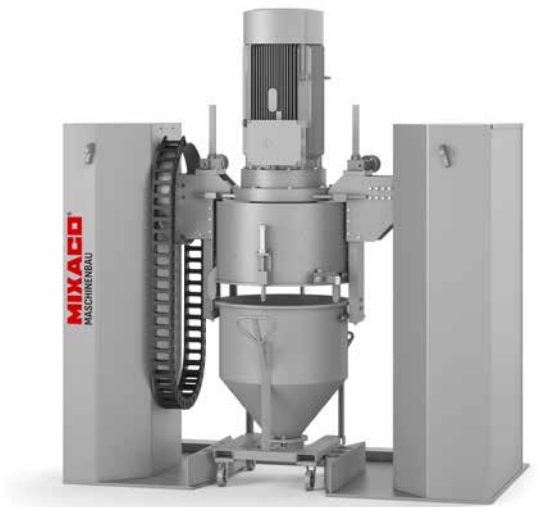

This cross-section of the mixing chamber illustrates the movement of material during the mixing process (vortex).



## Lab container mixer

### For small quantities with a big effect

The MIXACO lab container mixer is suitable for mixing small quantities. These are needed during product development as well as product monitoring. Despite its compact size, it offers all the benefits of a large container mixer. Particularly for use in labs, the container is very easy to transport with volumes of 6 or 12 liters.

With the corresponding tools and options, it is possible to perform all common mixing processes. This makes the MIXACO lab container mixer an optimal solution for developing new recipes that need to rapidly pass into industrial production.



# Tools

## Best mixing quality for a wide variety of applications

POWDER COATING | MASTERBATCH | COMPOUNDS | PVC | AND MANY MORE



### BR | Bottom blade tool

- Powder coating premixes, granules with granules, powder with powder, granules with powder
- 5-10 m/s



### D | Dispersion tool

- Powder coating premixes, color concentrates, masterbatch
- Mixing tool: 5-10 m/s, Blade: 25 m/s



### CD | Color dispersion tool

- Mixing temperature-sensitive materials, such as PTFE premixes
- Mixing tool: 5-10 m/s, Chopper: ca. 40 m/s



### CC | Color concentrate tool

- Color concentrates, masterbatch
- 25-40m/s



### MB | Masterbatch tool

- Color concentrates, masterbatch, toner, powder coating premix
- 15-20 m/s



### SM | High speed mixing tool

- PVC, masterbatch, SPC
- 20-40 m/s

# Details

## Container locking

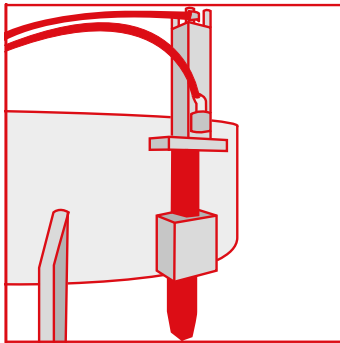

The container is positioned to the mixing head using a pneumatically activated lock.

## Jacketed mixing head

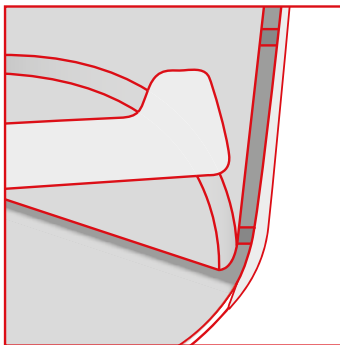

Enables tempering for heating or cooling of the product.

## Spindle lifting drive

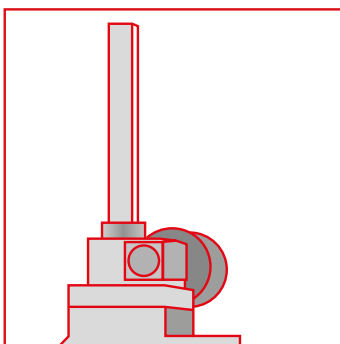

For raising and lowering the container to and from the mixing head.

## Air-gap seal

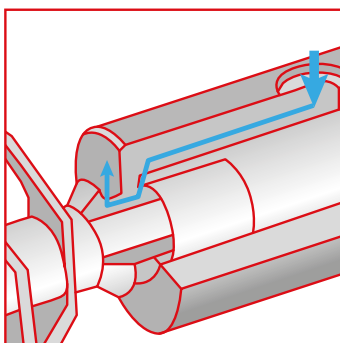

Contactless sealing for a rapidly circulating auxiliary tool shaft.

# Options

## Dedusting

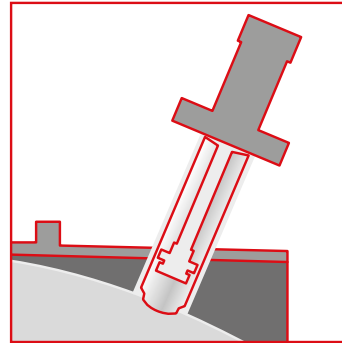

Dedusting equipment on the mixing head that extracts the fine dust generated in the mixing container after the mixing process.

## ATEX

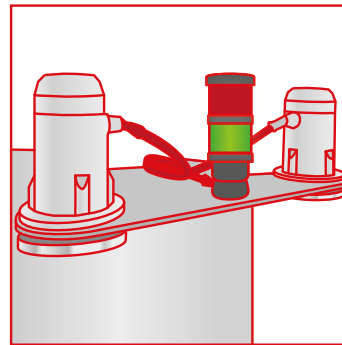

The container mixer can be designed for applications involving an explosion hazard according to the customer specifications in compliance with ATEX.

## Temperature sensor

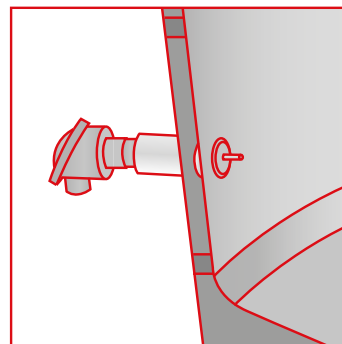

Temperature sensor in the mixing head to determine the product temperature during mixing. The temperature is indicated on the operating panel.

## Injection

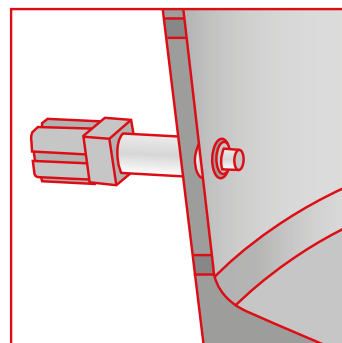

A pneumatically activated device in the mixing head for adding liquid or gaseous substances. The design of the injection tool can be adjusted specifically for the customer, for instance longer / thinner.



# Control

Our mixing equipment is controlled with a Siemens S7 PLC and meets today's requirements for safety, efficiency and cost-effectiveness. Since the control is developed and programmed by one and the same company, it is virtually ensured that the mixer components are optimally integrated. Alternatively, you can also use Allen Bradley components (incl. the Panelview operating panel). Control can also be designed according to UL / NEMA. Additionally, the control can be equipped with an interface for data exchange with higher-level control.



## Siemens TP700

- Using the touch control panel TP700, up to 99 mixing programs can be created in table form with ten work steps each.
- Data recording and storing measured values



## Allen Bradley

- Control according to UL / NEMA standards with an Allen Bradley PLC and a Panelview operating panel

## Remote maintenance module

The remote maintenance module enables fast and secure access to the combined mixer controller via a VPN tunnel. This in turn allows our service team to diagnose and rectify any malfunctions without having to visit the site.

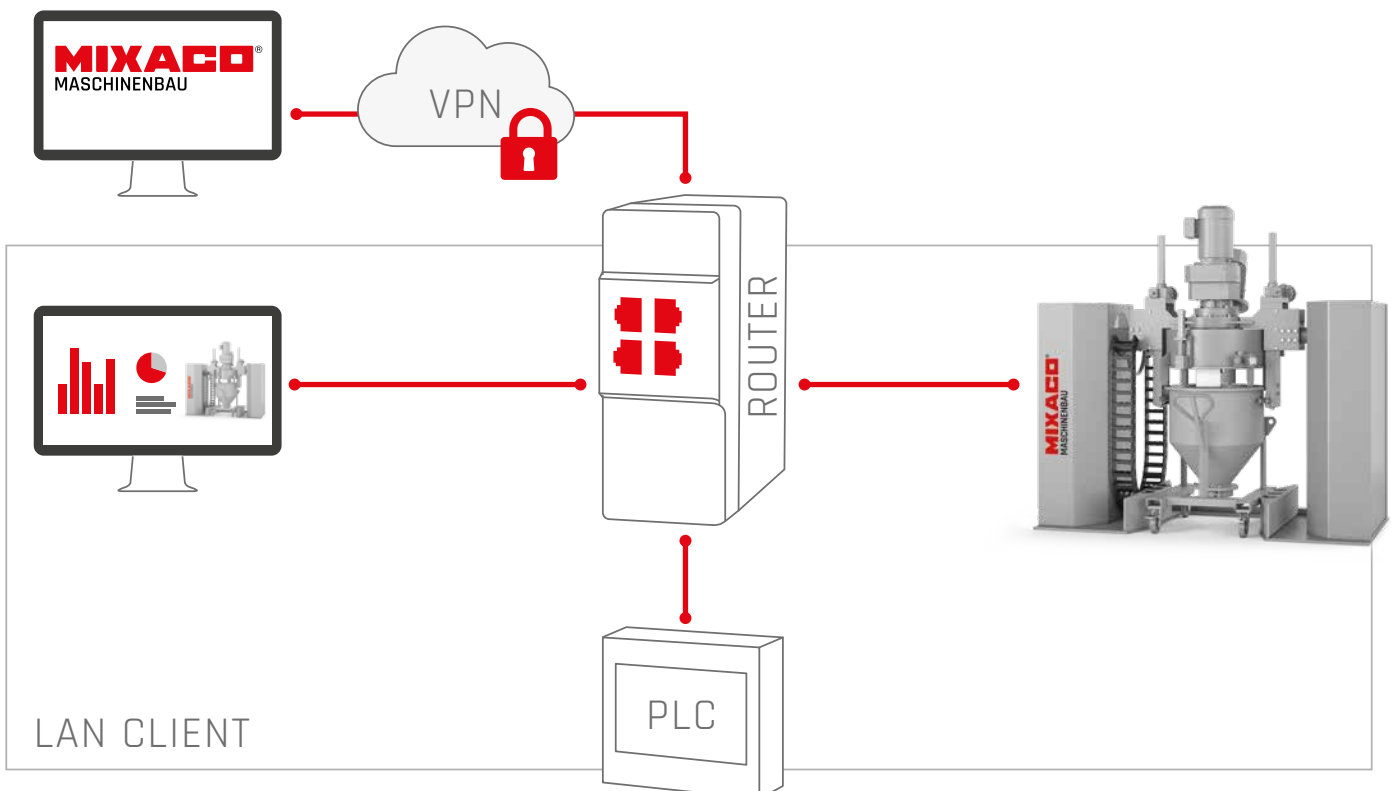

# MIXACO Accessories – Charging

The charging equipment developed by MIXACO is suitable for charging the mixing container with product without generating dust.

Depending on the customer requirements, various designs are available.

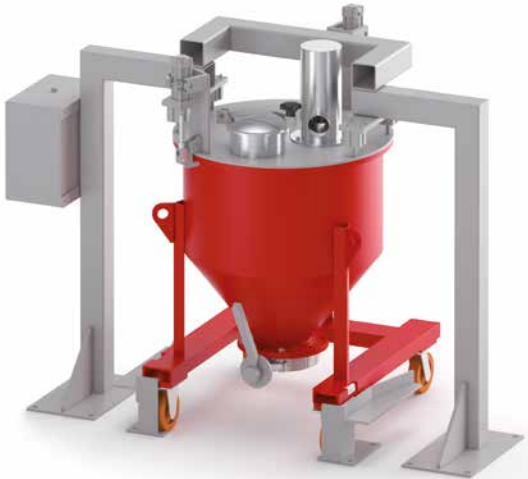

## Charging station

The charging station is used for filling the mixing container without generating dust. Combined with a floor scale or dosing system, it is possible to achieve automatic, semi-automatic or manual filling with raw materials.



## Charging table

The charging table is intended for manual charging of the container. Filling can be controlled using a platform scale and small-component scale (optional) combined with a weighing terminal. Extraction equipment guarantees that the container is filled without dust.

### Options for charging station

- Floor scale
- Cover clamping device for dust-free filling
- Feed funnel (can be closed with cover)

### Options for charging table

- Floor scale
- Table scale for small components
- Scissor lift table

# MIXACO Accessories – Discharging

The discharging stations developed by MIXACO are suitable for dust-free emptying of the mix into the machine where it will be further processed (e.g. extruder dosing). The container is fixed in the discharging station.

Two different designs are available. They vary in the type of container insertion.

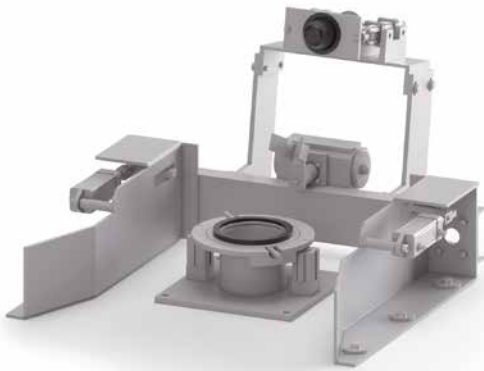

## Guide fork type

The mobile container is pushed into the discharging station and fixed in place. The down pipe is connected to the container outlet using a pneumatic coupling.

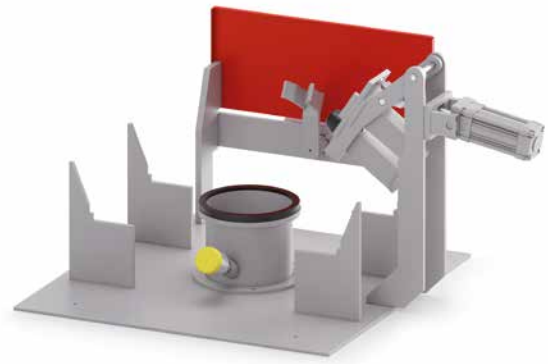

## Platform type

The container is placed on the discharging station using lifting equipment (crane or forklift).

## Options

- Pneumatically or electrically controlled
- Pneumatically rotating cylinder to open/close the container discharge valve, stepless opening
- Sensor for product monitoring in the downpipe
- Replaceable down pipe for faster recipe changes
- Vibratory motor or knocker to support the discharging process for poorly flowing products
- Control of discharging station, external or local
- Safety fence for discharging station

# Safety at the workplace



## Mixing cabin

To protect the plant operator during the tilting operation, the equipment is positioned in a mixing cabin. Operation is only possible when the cabin door is closed (integrated door limit switch).

# Technical Data

## Best mixing quality for a wide variety of applications

POWDER COATING | MASTERBATCH | COMPOUNDS | PVC | AND MANY MORE

### Various applications

For a wide variety of mixing processes:

- Homogenization
- Dispersing
- Wetting
- Disintegrating and dyeing of fibers

### Maximum functionality

Additional options:

- Wear protection for the tools
- Extraction in mixing position
- Compatibility with existing systems and containers
- Liquid injection
- Option of adding material in mixing position
- Exchangeable mixing head system
- Expanded stainless steel design of the container mixer
- Special painting
- ViwateQ<sup>®</sup> coating
- AGV (automatic guided vehicle) compatibility
- ATEX version:
  - Filling level measurement
  - Nitrogen inerting
  - Oxygen concentration measurement
- Data recording and analysis
- Remote maintenance

Sizes	Usable volume Liters	Batch size kg	Mixing time min / batch
<b>Lab container mixer</b>			
LAB CM 6	4.8	3	3-6
LAB CM 12	9.6	6	3-6
<b>Multitool™ / Vortex™ container mixer</b>			
CM 50	40	24	3-6
CM 150	120	70	3-6
CM 300	240	140	3-6
CM 450	360	210	3-6
CM 600	480	280	3-6
CM 800	640	380	3-6
CM 1000	800	480	3-6
CM 1300	1040	620	3-6
CM 2000	1600	960	3-6

Parameters	
Bulk density	0.6 kg/l
Filling level	min. 55 % * max. 80 % * only for Multitool™
Charging	manual
Additional sizes available on request	

# Experience in Many Industries

MIXACO has been offering solutions for a wide variety of industries for many decades. This means the requirements on the mixing technology are correspondingly varied. MIXACO has profound expertise across many industries and can precisely and positively adapt the wide product assortment to each individual mixing task.

Particularly when it comes to combined mixers, customers can benefit from comprehensive advice and customer-specific solutions. Whether new projects or the optimization of existing plants, MIXACO will be by your side throughout a successful installation and commissioning.

No other company stands for innovation in mixing technology like MIXACO, who has been setting new standards with its machinery and solutions for decades. Leading companies from numerous industries worldwide trust in MIXACO products.



Powder Coatings /  
Bonding



Masterbatches



Food Industry



Rubber Industry



Paint Industry



Building Materials

## Save the Best for Last

### All advantages at a glance:

- More efficient material logistics due to material transport in the mixing container
- User-friendly thanks to ergonomically optimized cleaning in preconfigured cleaning position
- Can be used for a wide variety of mixing tasks with many tool and motor combinations
- Technology and components are also designed for operation across multiple stories

### Additional advantages of **CM Multitool™**

- Minimal heating of the products
- Optimal homogenization
- Adjustable degree of desintegration
- No melting and adhesion
- Reduction of cleaning times

### Additional advantages of **CM Vortex™**

- Heating of the mix
- Optimal homogenization
- Suitable for many mixing products
- Proven mixing technology

Good ideas are conceived.  
But the right solutions are put to the test.



Contact us for your mixing trials and benefit from the extensive experience of our design and application engineers:

- Tests on various mixing systems
- Adaptation of mixing parameters
- Recording and documentation of mixing tests
- Analysis of mixing results



## MIXACO

Dr. Herfeld GmbH & Co. KG

Niederheide 2  
58809 Neuenrade  
Germany

Phone +49 2392 9644-0  
Fax +49 2392 62013  
info@mixaco.de

MIXACO USA LLC

1784 Poplar Drive  
Greer, SC 29651  
USA

Phone +1 864 331 23 20  
Fax +1 864 331 23 21  
info@mixaco.com